

**Montageanleitung
Installation instructions
Instruction de montage
Istruzione di montaggio
Instrucciones de montaje
Instruções de montagem
Montagevoorschrift
Instrukcja montażu**

SHOWERbox

<p>D Vor Montage Produkt auf Schäden und Vollständigkeit prüfen. Schäden durch Montage erkennbar unvollständig oder mangelhafter Produkte können nicht übernommen werden. Montageanleitung bitte nach der Montage dem Endkunden übergeben.</p>	<p>GB Before assembly, check the product for damage and completeness. Damage caused by assembling products that are recognisably incomplete or faulty will not be accepted. After assembly, please hand over the assembly instructions to the end customer.</p>	<p>F Avant le montage, vérifiez que le produit est complet et en bon état. Les dégâts causés par le montage ou les produits défectueux ne pourront pas être repris une fois montés. Une fois le montage terminé, merci de donner la notice au client final.</p>	<p>I Prima di eseguire il montaggio verificare le condizioni dell'articolo e accertare la presenza di eventuali danni. Gli articoli che presentano danni conseguenti al montaggio, difettosi o incompleti non potranno essere restituiti. Al termine del montaggio consegnare le relative istruzioni al cliente finale.</p>
<p>E Antes del montaje del producto comprobar si está completo y no presenta daños. No nos podemos hacer responsables de los daños producidos por el montaje de productos obviamente defectuosos o incompletos. Entregue las instrucciones de montaje al cliente final una vez haya concluido el montaje.</p>	<p>P Antes da montagem da cabina é favor verificar se o conteúdo está completo e se o mesmo se encontra danificado. Posteriormente, não serão aceites reclamações devido a deficiências de montagem, produtos incompletos ou defeituosos. Após a montagem, é favor entregar as respectivas instruções ao cliente.</p>	<p>NL Voor de montage het product zorgvuldig controleren en eventuele tekortkomingen direct aan de leverancier melden. In geval van schade dient de verpakking bewaard te blijven. Voor schade aan reeds gemonteerde producten wordt geen verantwoordelijkheid aanvaard! De montagehandleiding na het monteren aan de eindgebruiker geven. Hierin staan de bestelgegevens voor onderdelen.</p>	<p>PL Przed montażem produkt musi być sprawdzony pod względem uszkodzeń. Uszkodzenia zgłoszone po zamontowaniu produktu nie mogą być podstawą reklamacji. Instrukcję montażu proszę przekazać klientowi końcowemu.</p>

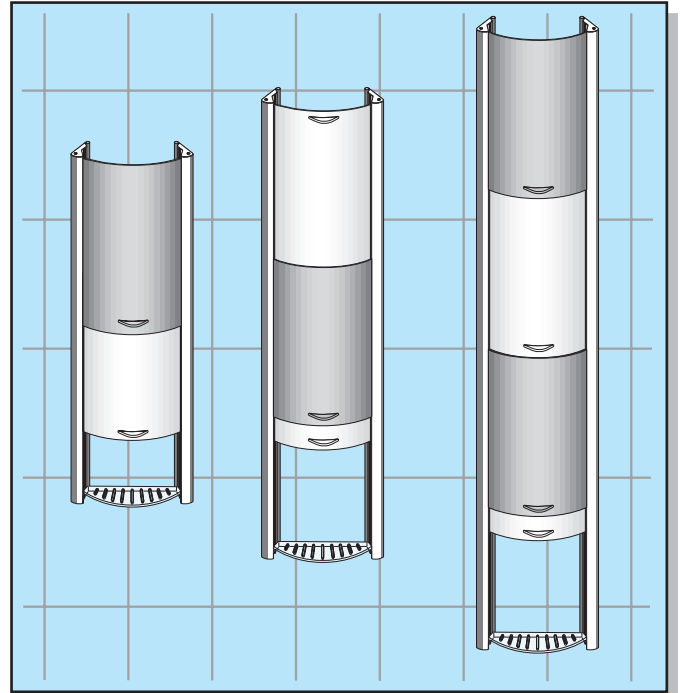

<p>Verpackungsinhalt Package content Contenu de l'emballage Contenuto imballo Contenido del embalaje Conteúdo da embalagem Verpakkingsinhoud Zawartość opakowania</p>	<p>Benötigtes Werkzeug (nicht enthalten) Necessary tools (not included) Outil Nécessaire (non fourni) Attrezzature necessaria (non inclusa)</p>	<p>Herramientas necesarias (no incluidas) Ferramentas necessárias (não incluidas) Gereedschap (niet ingesloten) Niezbędne narzędzia (nie zawarte w opakowaniu)</p>
		<p>Ø 4 mm</p>

Zubehör Equipment	Accessoires Accessori	Accesorios Acessorios	Toebehoren Zestaw montażowy
751610			
 4 x 251128			
 4 x 3 x 35 601225	 4 x 3,7 / 8 x 0,5 610431	 4 x 201181	
		<p>2x 3x 4x</p>	<p>201179</p>

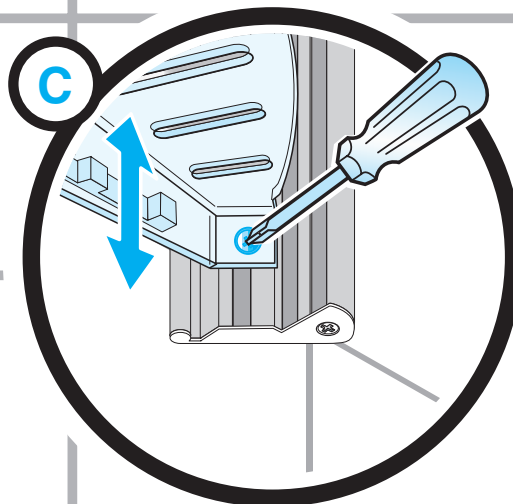
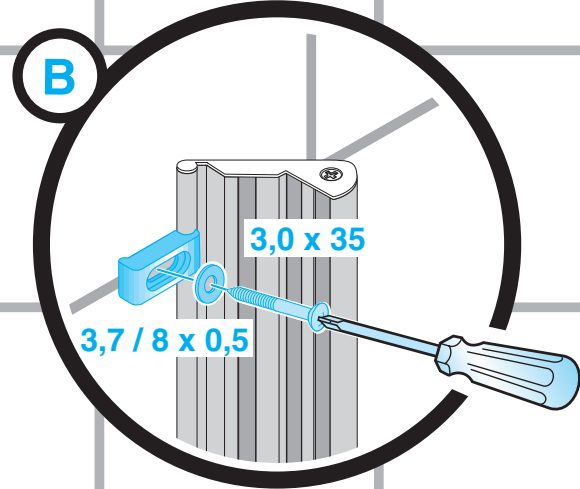
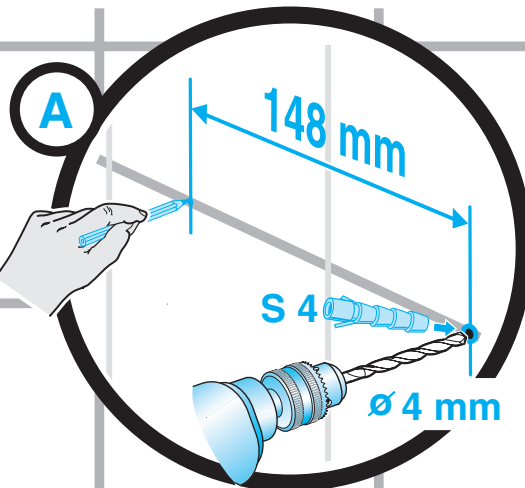
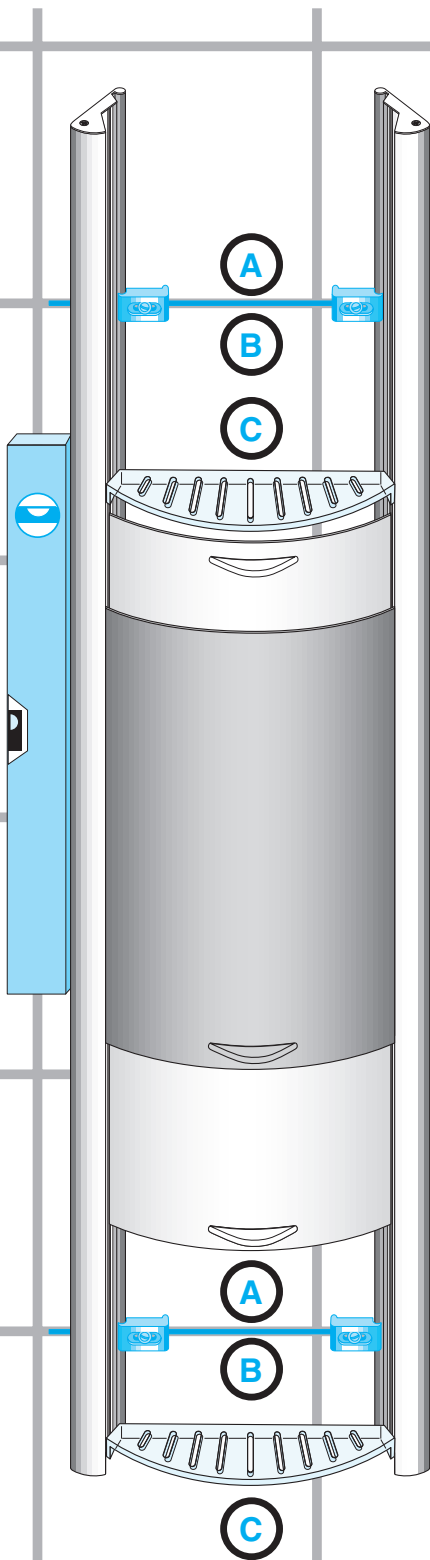
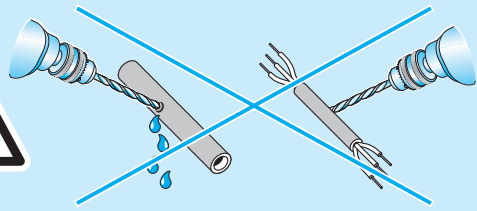
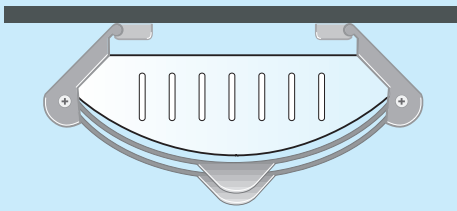

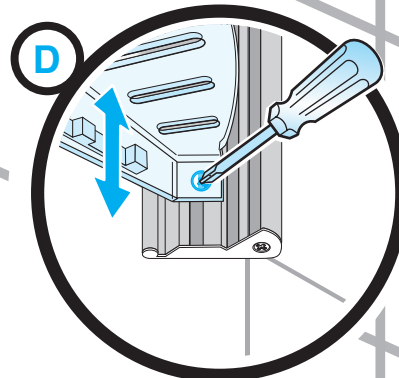
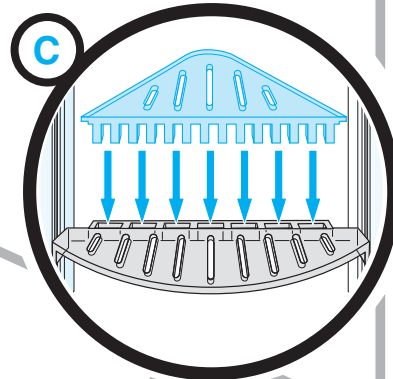
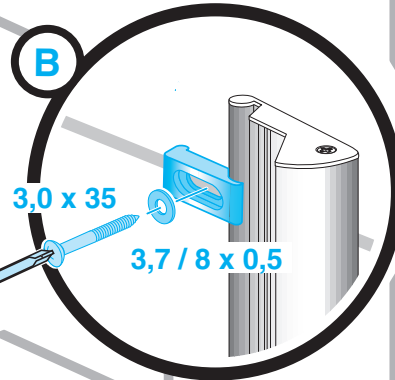
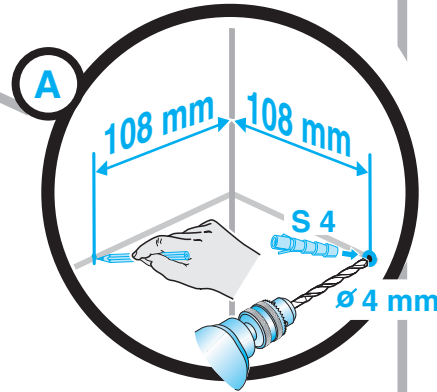
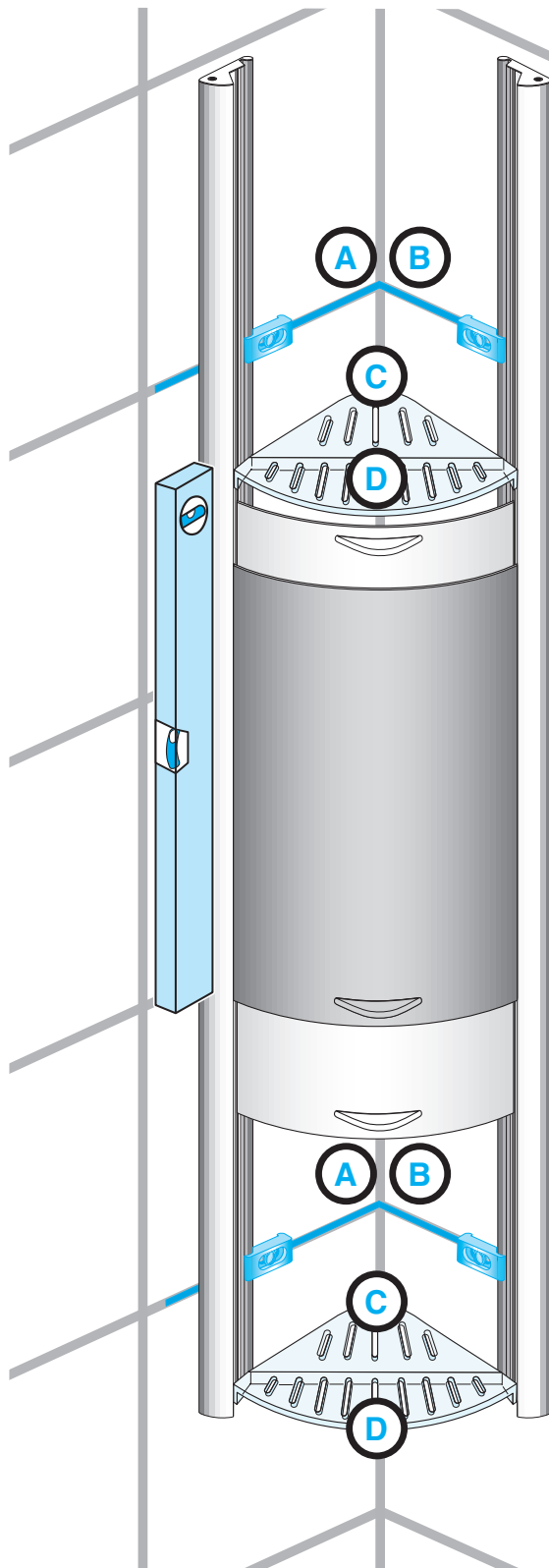
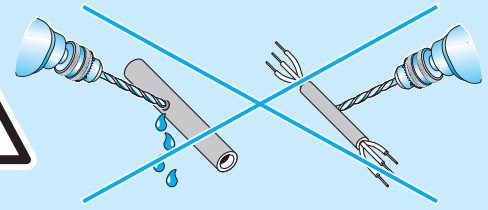
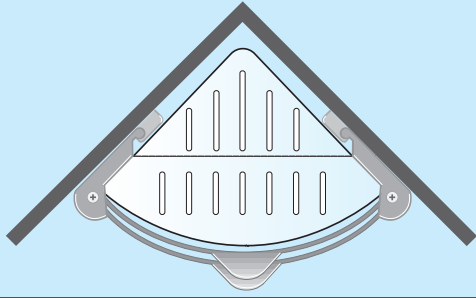

SHOWERbox

